

17610

11920

4 Hours / 100 Marks

Seat No.

--	--	--	--	--	--	--	--	--

- Instructions :**
- (1) All Questions are *compulsory*.
 - (2) Answer each next main Question on a new page.
 - (3) Illustrate your answers with neat sketches wherever necessary.
 - (4) Figures to the right indicate full marks.
 - (5) Assume suitable data, if necessary.
 - (6) Use of Non-programmable Electronic Pocket Calculator is permissible.
 - (7) Mobile Phone, Pager and any other Electronic Communication devices are not permissible in Examination Hall.

Marks

1. (a) Attempt any THREE of the following : 12

- (i) Explain Factor Of Safety (FOS). Write four factors on which FOS depends.
- (ii) Explain the purpose of turn buckle. State its application.
- (iii) A shaft is required to transmit 1 MW power at 240 rpm. The shaft must not twist more than 1 degree on a length of one meter. If the modulus of rigidity for the material of shaft is 80 kN/mm^2 . Find the diameter of shaft and shear stress induced on it.
- (iv) Explain self locking and over-hauling of power screws.

[1 of 4]

P.T.O.

- (b) **Attempt any ONE :** 06
- (i) State & explain the steps involved in general design procedure.
 - (ii) A flange coupling is used to transmit 20 kW power at 700 rpm. The flanges are of cast iron and other parts are of mild steel. Determine diameter of shaft, diameter of bolts assuming number of bolts are 6 and flange dimension.
Take – (1) Shear stress for mild steel = 40 N/mm²
(2) Shear stress for cast iron = 10 N/mm²
(3) Tensile & crushing stress = 100 N/mm²
2. **Attempt any TWO of the following :** 16
- (a) Design a knuckle joint to transmit 150 kN power. The design stresses may be taken as 75 MPa in tension, 60 MPa in shear and 150 MPa in compression.
 - (b) Compare the weight, strength and stiffness of a hollow shaft of the same external diameter as that of solid shaft. The inside diameter of hollow shaft being half the external diameter. Both the shaft have the same material and length.
 - (c) (i) Define :
(1) Ductility (2) Stiffness (3) Elasticity (4) Malleability 4
(ii) Draw a neat sketch of hand lever. Why levers are tapered at the ends ? 4
3. **Attempt any FOUR of the following :** 16
- (a) Suggest suitable material for the following machine parts :
 - (i) Crank shaft
 - (ii) Helical spring
 - (iii) Bushes for knuckle pin
 - (iv) Lathe bed

17610

[3 of 4]

- (b) Why taper is provided on cotter ? State its normal value. Write two application of cotter joint.
- (c) Write design procedure for sunk key.
- (d) Compare welded joints with screwed joint. (any four points)
- (e) Explain the gear tooth failure modes : (i) scoring (ii) pitting
4. (a) Attempt any **THREE** of the following : 12
- (i) Define Ergonomics. State area covered under ergonomics.
- (ii) Define following terms with respect to springs : (1) Free length (2) Solid length (3) Spring stiffness (4) Spring index
- (iii) How the keys are classified ? State the function of keys.
- (iv) State any four advantages & disadvantages of welded joint over riveted joint.
- (b) Attempt any **ONE** of the following : 06
- (i) Write design consideration for spur gear.
- (ii) Define endurance limit. Draw and explain typical S – N curve for steel.
5. Attempt any **TWO** of the following : 16
- (a) The lead screw of a lathe has square threads of 24 mm outside diameter and 5 mm pitch. In order to drive the tool carriage, the screw exerts an axial thrust of 2.5 kN find the efficiency of the screw and the power required to drive the screw if it is rotate at 30 rpm. Neglect the bearing friction. Assume co-efficient of thread friction as 0.12.
- (b) Design a helical compression spring for maximum load of 800 N for a deflection of 25 mm. The spring index is 5 and Wahl's correction factor is 1.3. The maximum permissible shear stress for the spring wire is 400 MPa. and modulus of rigidity is 84 kN/mm².

P.T.O.

- (c) (i) Give classification of bearing. 4
- (ii) Draw different types of thread profiles used for power screw. Write one application of each. 4
- 6. Attempt any FOUR of the following : 16**
- (a) A wall bracket is attached to a wall by means of four bolts, two at a distance of 50 mm from the lower edge and remaining two at a distance of 450 mm from the lower bolts. It supports a load of 50 kN at a distance of 500 mm from the wall. Find the diameter of bolts. Assume working stress in tension as 80 N/mm².
- (b) Explain with neat sketch construction details of leaf spring.
- (c) Explain with neat sketch the bolts of uniform strength.
- (d) Explain the procedure of selection of ball bearing using manufacturer's catalogue.
- (e) Define the following terms related to ball bearing :
- (i) Basic static load rating
- (ii) Basic dynamic load rating
-



WINTER – 19 EXAMINATION

Subject Name: Design of Machine Elements

Model Answer

Subject Code:

17610

Important Instructions to examiners:

- 1) The answers should be examined by key words and not as word-to-word as given in the model answer scheme.
- 2) The model answer and the answer written by candidate may vary but the examiner may try to assess the understanding level of the candidate.
- 3) The language errors such as grammatical, spelling errors should not be given more Importance (Not applicable for subject English and Communication Skills).
- 4) While assessing figures, examiner may give credit for principal components indicated in the figure. The figures drawn by candidate and model answer may vary. The examiner may give credit for any equivalent figure drawn.
- 5) Credits may be given step wise for numerical problems. In some cases, the assumed constant values may vary and there may be some difference in the candidate's answers and model answer.
- 6) In case of some questions credit may be given by judgement on part of examiner of relevant answer based on candidate's understanding.
- 7) For programming language papers, credit may be given to any other program based on equivalent concept.

Q. No.	Sub Q. N.		Marking Scheme
1.		Attempt any <u>THREE</u> of the following	12 marks
	(a)	<p>Factor of safety is a ratio of maximum stress withstand by an object to applied stress.</p> <p>Whenever a Factor of safety is greater than or equal to, then the applied stress is less than or equal to the maximum stress so the object can withstand load. But when the ratio is equal to 1, the object tough enough to withstand load.</p> <p>Whenever a Factor of safety is less than 1, the applied stress is greater than maximum stress then the object can't withstand the stress applied it leads to failure.</p> <p>The high factor of safety results in unnecessary risk of failure.</p> <p>There are many factors as</p> <p>1- materials strength (if the materials is a brittle or ductile)</p> <p>2-possible misuse: the designer must consider any responsible of for foreseeable use</p> <p>3-loading (static. impact, repeated).</p> <p>4- complexity of stress analysis</p> <p>5-cost</p> <p>6-environment and temperature, and this factor affect also to choose the materials.</p> <p>and we can say also each factor from the previous factors affects on another one its like a network and the designer person must know this Entanglement perfectly</p>	<p>02</p> <p>02</p>
	(b)	<p>A turnbuckle, stretching screw or bottle screw is a device for adjusting the tension or length of ropes, cables, tie rods, and other tensioning systems. It normally consists of two threaded eye bolts, one screwed into each end of a small metal frame, one with a left-hand thread and the other with a right-hand thread.</p> <p>Applications –</p>	<p>Explanation-</p> <p>02 Marks</p>



	<p>i) Aircraft-Turnbuckles have been used in aircraft construction, especially during the early years of aviation.</p> <p>ii) Shipping-Turnbuckles are used for tensioning a ship's rigging and lashings. This device is also known as a bottle screw</p> <p>iii) Sports-Turnbuckles find common use to tension the ropes in professional wrestling rings and boxing rings, where they serve as the attachment between the ring ropes and ring posts.</p> <p>iv) Entertainment industry-Turnbuckles are used in nearly all rigging performed in the entertainment industry, including theatre, film, and live concert performances.</p> <p>v) Pipe systems-Turnbuckles are used in piping systems as a way to provide minor adjustments for field inconsistencies.</p> <p>vi) Orthopaedics-A type of splint is used for upper limb to produce gradual stretching over contracted joint by its turn buckle mechanism.</p> <p>vii) Buffers and chain coupler</p> <p>viii) Guy-wire</p> <p>ix) Mechanical joint</p>	<p>Applications any 4 ½ M each</p>	
(c)	<p>Torque transmitted by the shaft $T = P \times 60 / 2\pi N = 1 \times 10^6 \times 60 / 2 \pi \times 240 = 39783.58 \text{ Nm}$ $= 39783.58 \times 10^3 \text{ N.mm}$</p> <p>We know that $T/J = G\theta/L$ or $J = TXL/GX\theta$</p> $\pi/32 \times d^4 = 39783.58 \times 10^3 \times 1000 / 80 \times 10^3 \times 0.0174 = 28580158$ $d^4 = 28580158 \times 32 / \pi = 291077357$ $d = 103.73 \text{ mm say } 110 \text{ mm} = 130.74 \text{ mm Say } 135 \text{ mm}$ <p>Shear stress induced in the shaft</p> <p>Torque transmitted by the shaft $T = \pi/16 \times \tau \times d^3 =$ put $d = 135 \text{ mm}$</p> $39783.58 \times 10^3 = \pi/16 \times \tau \times (110)^3$ $\tau = 148.15 \text{ N/mm}^2 = 148.15 \text{ MPa} = 82.36 \text{ MPa}$	<p>01</p> <p>01</p> <p>01</p> <p>01</p>	
(d)	<p>Self locking property - torque required to lower the load, $T = W \tan(\phi - \alpha) \times d/2$</p> <p>Self locking property of the threads-if $\phi > \alpha$ the torque required to lower the the load will be positive, indicating that an effort is applied to lower the load. if friction angle is greater than the helix angle or coefficient of friction is greater than the tangent of helix angle</p> <p>Over hauling of screws in the above expression, if $\phi < \alpha$, then the torque required to lower the load will be negative. The load will start moving downward without the application of any torque, such a condition is known as over hauling of screws.</p>	<p>2 Mark for each definition</p>	
1.	b	Attempt any ONE of the following	06 marks
	(i)	<p>1. Recognition of need. First of all, make a complete statement of the problem, indicating the need, aim or purpose for which the machine is to be designed.</p> <p>2. Synthesis (Mechanisms). Select the possible mechanism or group of mechanisms which</p>	



will give the desired motion.

3. Analysis of forces. Find the forces acting on each member of the machine and the energy transmitted by each member.

4. Material selection. Select the material best suited for each member of the machine. 5. Design of elements (Size and Stresses). Find the size of each member of the machine by considering the force acting on the member and the permissible stresses for the material used. It should be kept in mind that each member should not deflect or deform than the permissible limit.

6. Modification. Modify the size of the member to agree with the past experience and judgment to facilitate manufacture. The modification may also be necessary by consideration of manufacturing to reduce overall cost.

7. Detailed drawing. Draw the detailed drawing of each component and the assembly of the machine with complete specification for the manufacturing processes suggested. Prepare assembly drawing giving part numbers, overall dimensions and part list. The component drawing is supplied to the shop flow for manufacturing purpose, while assembly drawing is supplied to the assembly shop

8. Production. The component, as per the drawing, is manufactured in the workshop

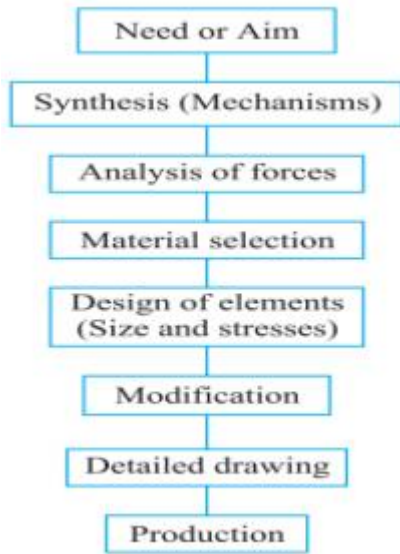

03 Mark

03 Mark

(ii)

1. To find torque acting on the shaft

$$T = P \times 60 / 2\pi N = 20 \times 10^3 \times 60 / 2\pi \times 700 = 272.80 \text{ Nm} = 272.80 \times 10^3 \text{ Nmm}$$

2. To find diameter of shaft to transmit required torque

$$T = \pi / 16 \times \tau \times d^3$$

$$272.80 \times 10^3 = \pi / 16 \times \tau \times d^3$$

$$d^3 = 32.62 \text{ mm say } 35 \text{ mm}$$

Check shear stress in hub

$$\text{Outside dia. of hub } D = 2d = 2 \times 35 = 70 \text{ mm}$$

$$T = \pi / 16 \times \tau_c \times d^3 \times (1 - k^4) = \pi / 16 \times \tau_c \times D^3 \times (1 - k^4)$$

01

01

01



	<p>Put the value $D=70\text{mm}$ instead of $d=35\text{mm}$</p> $272.80 \times 10^3 = \pi/16 \times \tau_c \times 35^3 \times (1-0.5^4)$ $\tau_c = 37.03 \text{N/mm}^2 = 4.32 \text{N/mm}^2$ <p>since induced stress is less than allowable shear stress</p> <p>Design Of Bolts</p> <p>No of Bolts $n=6$</p> <p>Pcd of bolts $D_1 = 3d = 3 \times 35 = 105 \text{ mm}$</p> <p>Torque transmitted $T = \pi/4 \times (d_1)^2 \times \tau_b \times n \times D_1/2$</p> $d_1 = 5.25 \text{ mm}$ <p>nearest standard core diameter of bolt from coarse thread is 5.7773mm</p>	01 01 01
2.	Attempt any <u>TWO</u> of the following	16 marks
(i)	<p>1. Failure of the solid rod in tension</p> <p>Let d = Diameter of the rod.</p> <p>We know that the load transmitted (P),</p> $150 \times 10^3 = \pi/4 \times d^2 \times \sigma_t = \pi/4 \times d^2 \times 75$ $= 59 d^2$ $\therefore d^2 = 150 \times 10^3 / 59 = 2540 \text{ or } d = 50.4 \text{ say } 52 \text{ mm Ans.}$ <p>Now the various dimensions are fixed as follows :</p> <p>Diameter of knuckle pin,</p> $d_1 = d = 52 \text{ mm}$ <p>Outer diameter of eye, $d_2 = 2 d = 2 \times 52 = 104 \text{ mm}$</p> <p>Diameter of knuckle pin head and collar,</p> $d_3 = 1.5 d = 1.5 \times 52 = 78 \text{ mm}$ <p>Thickness of single eye or rod end,</p> $t = 1.25 d = 1.25 \times 52 = 65 \text{ mm}$ <p>Thickness of fork, t</p> $1 = 0.75 d = 0.75 \times 52 = 39 \text{ say } 40 \text{ mm}$ <p>Thickness of pin head, $t_2 = 0.5 d = 0.5 \times 52 = 26 \text{ mm}$</p> <p>2. Failure of the knuckle pin in shear</p> <p>Since the knuckle pin is in double shear, therefore load (P),</p> $150 \times 10^3 = 2 \times \pi/4 \times (d_1)^2 \times \tau$ $\therefore \tau = 150 \times 10^3 / 4248 = 35.3 \text{ N/mm}^2 = 35.3 \text{ MPa}$ <p>3. Failure of the single eye or rod end in tension</p>	02 M



The single eye or rod end may fail in tension due to the load. We know that load (P),

$$150 \times 10^3 = (d_2 - d_1) t \times \sigma_t$$

$$= (104 - 52) 65 \times \sigma_t = 3380 \sigma_t$$

$$\therefore \sigma_t = 150 \times 10^3 / 3380 = 44.4 \text{ N/mm}^2 = 44.4 \text{ MPa}$$

4. Failure of the single eye or rod end in shearing

The single eye or rod end may fail in shearing due to the load. We know that load (P),

$$150 \times 10^3 = (d_2 - d_1) t \times \tau = (104 - 52) 65 \times \tau = 3380 \tau$$

$$\therefore \tau = 150 \times 10^3 / 3380 = 44.4 \text{ N/mm}^2 = 44.4 \text{ MPa}$$

5. Failure of the single eye or rod end in crushing

The single eye or rod end may fail in crushing due to the load. We know that load (P),

$$150 \times 10^3 = d_1 \times t \times \sigma_c$$

$$= 52 \times 65 \times \sigma_c = 3380 \sigma_c$$

$$\therefore \sigma_c = 150 \times 10^3 / 3380 = 44.4 \text{ N/mm}^2 = 44.4 \text{ MPa}$$

6. Failure of the forked end in tension

The forked end may fail in tension due to the load. We know that load (P),

$$150 \times 10^3 = (d_2 - d_1) 2 t_1 \times \sigma_t$$

$$= (104 - 52) 2 \times 40 \times \sigma_t = 4160 \sigma_t$$

$$\therefore \sigma_t = 150 \times 10^3 / 4160 = 36 \text{ N/mm}^2 = 36 \text{ MPa}$$

7. Failure of the forked end in shear

The forked end may fail in shearing due to the load. We know that load (P)

$$150 \times 10^3 = (d_2 - d_1) 2 t_1 \times \tau = (104 - 52) 2 \times 40 \times \tau = 4160 \tau$$

$$\therefore \tau = 150 \times 10^3 / 4160 = 36 \text{ N/mm}^2 = 36 \text{ MPa}$$

8. Failure of the forked end in crushing

The forked end may fail in crushing due to the load. We know that load (P),

$$150 \times 10^3 = d_1 \times 2 t_1 \times \sigma_c$$

$$= 52 \times 2 \times 40 \times \sigma_c = 4160 \sigma_c$$

$$\therefore \sigma_c = 150 \times 10^3 / 4180 = 36 \text{ N/mm}^2 = 36 \text{ MPa}$$

From above, we see that the induced stresses are less than the given design stresses, therefore the joint is safe.

02 M

02 M

02 M

(ii)

Given : $d_o = d$;

$$d_i = d_o / 2 \text{ or } k = d_i / d_o = 1 / 2 = 0.5$$

Comparison of weight



	<p>We know that weight of a hollow shaft, $W_H = \text{Cross-sectional area} \times \text{Length} \times \text{Density}$ $= \pi/4 [(d_o)^2 - (d_i)^2] \times \text{Length} \times \text{Density} \dots(i)$ and weight of the solid shaft, $W_S = \pi/4 d^2 \times \text{Length} \times \text{Density} \dots(ii)$ Since both the shafts have the same material and length, therefore by dividing equation (i) by equation (ii), we get $W_H/W_S = \pi/4 [(d_o)^2 - (d_i)^2] / \pi/4 d^2$ $= 1 - k^2 = 1 - (0.5)^2 = 0.75 \text{ Ans.}$ Comparison of strength We know that strength of the hollow shaft, $T_H = \pi/16 \times \tau (d_o)^3 - (d_i)^3 (1 - k^4)^3 \dots(iii)$ and strength of the solid shaft, $T_S = \pi/16 \times \tau \times d^3 \dots(iv)$ Dividing equation (iii) by equation (iv), we get $T_H/T_S = \pi/16 \times \tau (d_o)^3 - (d_i)^3 (1 - k^4)^3 / \pi/16 \times \tau \times d^3$ $= 1 - k^4 \quad (d = d_o)$ $= 1 - (0.5)^4 = 0.9375 \text{ Ans.}$ Comparison of stiffness We know that stiffness $= T/\theta = G J/L$ \therefore Stiffness of a hollow shaft, $S_H = G/L \times \pi/32 [(d_o)^4 - (d_i)^4] \dots(v)$ and stiffness of a solid shaft, $S_S = G/L \times \pi/32 d^4 \dots(vi)$ Dividing equation (v) by equation (vi), we get $S_H/S_S = G/L \times \pi/32 [(d_o)^4 - (d_i)^4] / G/L \times \pi/32 d^4 \dots (d = d_o)$ $= 1 - k^4 = 1 - (0.5)^4 = 0.9375 \text{ Ans.}$</p>	<p>02 M</p> <p>02 M</p> <p>02 M</p> <p>02 M</p>
(iii) a)	<p>1) Ductility is the physical property of a material associated with the ability to be hammered thin or stretched into wire without breaking. A ductile substance can be drawn into a wire. Examples: Most metals are good examples of ductile materials, including gold, silver, copper, erbium, terbium, and samarium.</p> <p>2) Stiffness-It is defined as the property of a material which is rigid and difficult to bend. The example of stiffness is rubber band.</p> <p>3) Elasticity-The elasticity of a material or substance is its ability to return to its original shape</p>	<p>1 Mark</p> <p>1 Mark</p> <p>1 Mark</p>

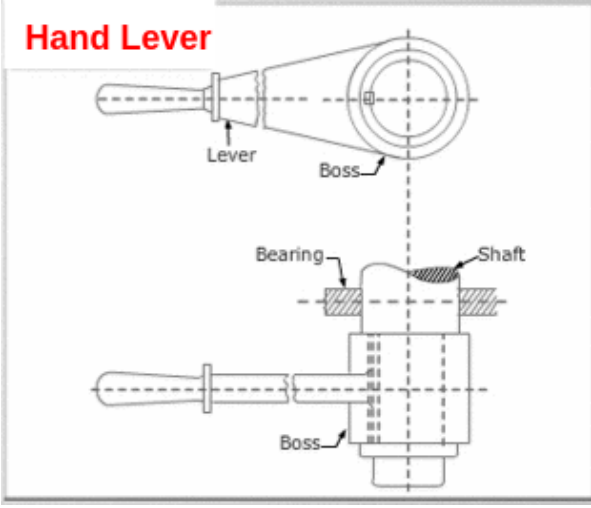

	4) Malleability is a substance's ability to deform under pressure (compressive stress). If malleable, a material may be flattened into thin sheets by hammering or rolling.	1 Mark
b)	 <p>In lever, the bending moment is maximum at the fulcrum and minimum at the ends. Therefore, the levers are usually tapered from the fulcrum to the ends. This would help in saving the material at the ends. Lever with fulcrum between load and effort.</p> <p>Bending moment is zero at the point of application of load. So the resisting area at this point is minimum and maximum, where the bending takes place. So levers are tapered to avoid stress concentration.</p>	2 Mark 2 Mark
3.	Attempt any <u>FOUR</u> of the following	16 marks
(a)	Suggest suitable material for the following machine parts.	
Ans	<p>i)Crank Shaft : Alloy steel 20Mn2 , 35 Mn2MO28</p> <p>ii)Helical spring : oil tempered carbon steel / chromium vanadium alloy steel</p> <p>iii)bushes for knuckle pin: Phosphorus bronze, Grey C.I</p> <p>iv)Lathe bed: Grey cast iron like FG150</p>	1 Mark each
(b)	Why taper is provided on taper? State the normal value. Write any two application of cotter joint.	
Ans	<p>i)When cotter is driven through the slots, it fit, tight due to wedge action. This ensures tightness of joint in operation and prevent loosening of the parts.</p> <p>ii) Due to taper, it is easy to remove the cotter and dismantle the joint.</p> <p>The normal value of taper varies from 1 in 48 to 01 in 24 and it may increase to 1 in 8.</p> <p>Application of cotter joint: 1) Lewis foundation bolt 2) connection of the piston rod to cross head of a reciprocating steam engine. 3) Valve rod & its stem 4) piston rod to the trail end in an air pump. 5) Cycle pedal sprocket wheel.</p>	Reason: 2 M Value : 1M Application: 1M
(c)	Write the design procedure of sunk key	
Ans		

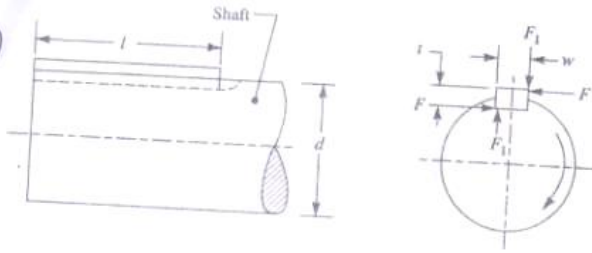

Considering a square key connecting the shaft hub.

Let, T = Torque transmitted by shaft

F = Tangential force acting at the circumference of

d = Diameter of shaft l = Length of key

w = Width of key

t = Thickness of key

for square key, we have,

$$w = t$$

Let τ , σ_c be the permissible shear and crushing stress for key material respectively.

A little consideration will show that due to power transmitted by the shaft the key may fail either due to shearing or crushing.

Considering shearing of key, the tangential shearing force acting on the shaft is

$$= \text{Area resisting shearing} \times \text{Shear stress} = l \times w \times \tau \dots\dots\dots(a)$$

Also, Torque transmitted =

Considering crushing key, the tangential crushing force acting on the shaft is,

Fix the dimension of key from the standard shaft diameter, and as per the requirement square or rectangular key can be selected,

w = width of key

t = thickness of key

l = length of key = **1.5d** by proportion.....(1)

1. **For Square key**, $w=t=d/4$(b)

2. **For rectangular key**, $w=d/4$ & $t=2/3w$(c)

3. & length of key can be obtained **by shearing and crushing failure of key.**

Considering shearing of key,

$$T = \tau \times w \times l \times d/2 \dots\dots\dots(2)$$

1M

1M

1M



		Considering crushing failure of key, $T = \sigma_c \times l \times d / 2 \times t / 2 \dots \dots \dots (3)$	1M
	(d)	Compare welded joints with screwed joints. (Any Four Points)	
	Ans	(i) Screwed joints require additional elements like washers and a large number of nut bolts, which increase the weight. Since there are no such additional parts, welded assembly results in lightweight construction. Welded steel structures are lighter compared to threaded joints. (ii) Due to the elimination of these components, the cost of welded assembly is lower than that of screwed joints. (iii) The design of welded assemblies can be easily and economically modified to meet the Changing product requirements. Alterations and additions can be easily made in the existing structure by welding. (iv) Welded assemblies are tight and leak-proof as compared with screwed assemblies. Welded assemblies are tight and leak-proof as compared with screwed assemblies.	1 M each
	(e)	Explain the gear tooth failure modes 1) scoring 2) pitting	
	Ans	<p>i) SCORING:</p> <ul style="list-style-type: none"> • Scoring is due to combination of two distinct activities: First, lubrication failure in The contact region and second, establishment of metal to metal contact. • Later on, welding and tearing action resulting from metallic contact removes the metal rapidly and continuously so far the load, speed and oil temperature remain at the same level. • The scoring is classified into initial, moderate and destructive. <p>ii) Pitting:</p> <ul style="list-style-type: none"> • This is a major cause of gear failure accounting for nearly 60% of the gear failures. • Pitting is the formation of craters on the gear tooth surface. These craters are formed due to the high amount of compressive contact stresses in the gear surface occurring during transmission of the torque or in simple terms due to compressive fatigue on the gear tooth surface. • The pitting starts when total load acting on the gear tooth exceeds the wear strength of the gear tooth. 	<p>2 M</p> <p>2 M</p>
4.	A	Attempt any <u>THREE</u> of the following	12 marks
	(a)	Define Ergonomics .state areas covered under ergonomics	
	Ans	Ergonomics: It is defined as the relationship between man & Machine and the application of anatomical, physiological & Psychological principles to solve the problems arising from man-	Def: 2M



	<p>machine relationship.</p> <p>Following areas are covered under ergonomics:</p> <p>The relation between man and machine</p> <p>The working environment</p> <p>The human anatomy and posture while using the machine</p> <p>The energy expenditure in hand and foot operations</p>	Areas: 2M
(b)	Define the following terms with respect to spring	
Ans	<p>1) Free length : is the length of the spring in the free or unloaded condition. It is equal to the solid length plus the maximum deflection or compression of the spring and the clearance between the adjacent coils</p> <p>Free length of the spring,</p> $L_F = \text{Solid length} + \text{Maximum compression} + \text{*Clearance between adjacent coils}$ $L_F = n' \cdot d + \delta_{\max} + 0.15 \delta_{\max}$ <p>2) Solid length : The solid length of a spring is the product of total number of coils and the diameter of the wire.</p> <p>Mathematically, Solid length of the spring, $L_s = n' \cdot d$</p> <p>where n' = Total number of coils, and d = Diameter of the wire</p> <p>3) Spring stiffness : The spring stiffness or spring constant is defined as the load required per unit deflection of the spring.</p> <p>Mathematically, Spring rate, $k = W / \delta$</p> <p>Where, W = Load, and δ = Deflection of the spring.</p> <p>4) Spring index: The spring index is defined as the ratio of the mean diameter of the coil to the diameter of the wire.</p> <p>Mathematically, Spring index, $C = D / d$</p> <p>where D = Mean diameter of the coil, and</p> <p>d = Diameter of the wire.</p>	1 M each term
(c)	How the keys are classified? State the function of keys.	
Ans	<p>Keys are classified as follows</p> <p>1) Sunk Key : a) Rectangular sunk key b) square sunk key c) Gib head key d) feather key e) Woodruff key</p>	Classification:2M



	<p>2) Saddle key : a) Flat saddle key b) hollow saddle key</p> <p>3) Round key</p> <p>4) Splines</p> <p>Functions of Key:</p> <p>a) To transmit torque from shaft to hub of mating element such as pulley, gear etc.</p> <p>b) To prevent relative motion between the shaft & mating machine element</p>	Fun: 2 M
(d)	State any four advantages & disadvantages of welded joints over riveted joint	
Ans	<p>Advantages:</p> <ol style="list-style-type: none">1. The welded structures are usually lighter than riveted structures. This is due to the reason, that in welding, gussets or other connecting components are not used.2. The welded joints provide maximum efficiency (may be 100%) which is not possible in case of riveted joints.3. Alterations and additions can be easily made in the existing structures.4. As the welded structure is smooth in appearance, therefore it looks pleasing.5. In welded connections, the tension members are not weakened as in the case of riveted joints.6. A welded joint has a great strength. Often a welded joint has the strength of the parent metal itself.7. Sometimes, the members are of such a shape (<i>i.e.</i> circular steel pipes) that they afford difficulty for riveting. But they can be easily welded.8. The welding provides very rigid joints. This is in line with the modern trend of providing rigid frames.9. It is possible to weld any part of a structure at any point. But riveting requires enough clearance.10. The process of welding takes less time than the riveting.	1 M each (Any four pt)
B	Attempt any <u>ONE</u> of the following	06 marks
(a)	Write the design consideration for spur gear	
Ans	<ol style="list-style-type: none">1) The power to be transmitted2) The velocity ration or speed of gear drive.3) The central distance between the two shafts4) Input speed of the driving gear.5) Wear characteristics of the gear tooth for a long satisfactory life.6) The use of space & material should be economical.7) Efficiency & speed ratio Cost	1 M each
(b)	Define endurance limit .Draw and explain typical S-N curve for the steel.	
Ans	<p>Endurance Limit: It is defined as maximum value of the completely reversed bending stress which a polished standard specimen can withstand without failure, for infinite number of cycles (usually 10⁷ cycles).It is known as endurance or fatigue limit (σ_e).</p>	Def: 2 M

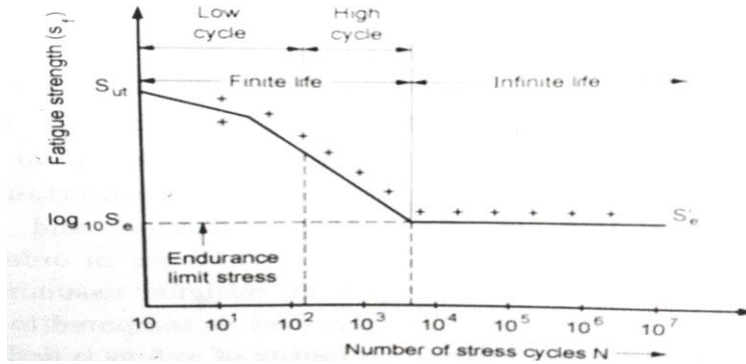

Sketch 2 M

The plot of fatigue strength S_f Vs stress cycle N on log paper. This plot is popularly known as S-N Diagram. For the steel material, the graph becomes horizontal at 10^6 cycles, indicating that the fatigue failure will not occur below this stress, whenever may be the number of cycles. This stress is known as endurance limit S_f of the material.

Explain 2M

5. Attempt any **TWO** of the following

16 marks

5. (a) The lead screw of a lathe has square threads of 24 mm outside diameter and 5 mm pitch. In order to drive the tool carriage, the screw exerts an axial thrust of 2.5 kN. Find the efficiency of the screw and the power required to drive the screw if it rotates at 30 rpm. Neglect the bearing friction. Assume coefficient of thread friction as 0.12

8 marks

Ans $W = 2.5 \text{ kN} = 2.5 \times 10^3 \text{ N}$.

Outside Diameter = $d_o = 24 \text{ mm}$.

Pitch = $p = 5 \text{ mm}$.

$\tan \phi = \mu = 0.12$

$N = 300 \text{ rpm}$.

Inside Diameter = $d_c = d_o - p = 24 - 5 = 19 \text{ mm}$.

Mean Diameter = $D_m = \frac{d_o + d_c}{2} = \frac{24 + 19}{2} = 21.5 \text{ mm}$.

01 Mark

$\tan \alpha = \frac{p}{\pi D_m} = \frac{5}{\pi \times 21.5} = 0.074$

01 Mark

$\alpha = 4.232^\circ$

$\phi = \tan^{-1} \mu = \tan^{-1}(0.12)$

01 Mark

$\phi = 6.8427^\circ$

Torque required to overcome the friction,

01 Mark

$T_1 = W \tan(\phi + \alpha) \frac{D_m}{2}$

(c) (i)	Give classification of bearing.	4 marks
Ans	<div style="text-align: center;"> <p align="center">OR</p> <p>Depending upon the nature of contact:</p> <ol style="list-style-type: none"> Sliding contact bearings. Rolling contact bearings. <p>depending upon the direction of load to be supported :</p> <ol style="list-style-type: none"> Radial bearings. Thrust bearings. </div>	01 Mark for each sub type
(ii)	Draw different types of thread profiles used for power screw. Write one application of each.	4 Marks
Ans		<p>½ mark for each dia.</p> <p align="center">&</p>



		Applications: 1. Square threads: i. Screw jacks, ii. Mechanical press, iii. Clamping devices. 2. Acme threads: i. Used in lead screw of machine tools, ii. Brass valves, iii. Cocks, iv. Bench vices. 3. Trapezoidal threads: i. Lead screws, etc 4. Buttress threads: i. Artillery, ii. Breechblock, etc.	½ mark for each type application
6		Attempt any <u>FOUR</u> of the following	16 Marks
6	(a)	A wall bracket is attached to a wall by means of four bolts, two at a distance of 50 mm from the lower edge and remaining two at a distance of 450 mm from the lower bolts. It supports a load of 50 kN at a distance of 500 mm from the wall. Find the diameter of bolts. Assume working stress in tension as 80 N/mm ² .	04 Marks

Given : $\sigma_t = 80 \text{ N/mm}^2$

Load = $W = 50 \text{ kN} = 50 \times 10^3 \text{ N}$

$L = 500 \text{ mm}$

$L_1 = 50 \text{ mm}$

$L_2 = 50 + 450 = 500 \text{ mm}$

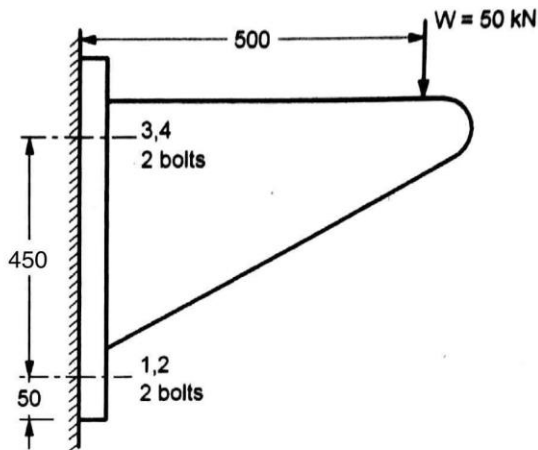

Number of bolt = $n = 04$

From Fig. P. 4.16.3, load is perpendicular to the axis of bolt

1. Direct shear load (W_s)

$$W_s = \frac{W}{n} = \frac{50 \times 10^3}{4}$$

$$W_s = 12500 \text{ N} = 12.5 \text{ kN}$$

2. Maximum tensile load carried by bolt 3 and 4 at a distance L_2 .

As load 'W' will try to tilt the bracket in the clockwise direction, the bolt, 3 and 4 is at greatest distance about tilting edge.

\therefore Maximum tensile load (W_t)

$$W_t = \frac{WL L_2}{2 [L_1^2 + L_2^2]} = \frac{50 \times 10^3 \times 500 \times 500}{2 [(50)^2 + (500)^2]}$$

$$= 24752.47525 \text{ N} = 24.752 \text{ kN}$$

Since the bolts are subjected to direct shear and tensile load, so the equivalent tensile load

$$W_{te} = \frac{1}{2} [W_t + \sqrt{W_t^2 + 4 W_s^2}]$$

01 Mark

01 Mark



$$= \frac{1}{2} [24.75 + \sqrt{(24.75)^2 + 4(12.5)^2}]$$
$$= 29.964 \text{ kN}$$

To find side of bolt

$$\sigma_t = \frac{W_{te}}{\frac{\pi}{4} d_c^2}$$

$$80 = \frac{29.964 \times 10^3}{\frac{\pi}{4} \times d_c^2}$$

$$d_c^2 = 476.899$$

$$d_c = 21.838 \text{ mm}$$

$$\text{Nominal diameter of bolt} = \frac{d_c}{0.84} = 25.997$$

$$\cong 26 \text{ mm}$$

The size of bolt = M26

01 Mark

01 Mark

(b) Explain with neat sketch construction of leaf spring.

04 marks

Ans

- Semi-elliptical leaf springs are widely used for suspension in light and heavy commercial vehicle. In car these are used for rear suspension.
- The leaf springs are made of flat semi-elliptical plate.
- The advantage of leaf spring over helical spring is that the ends of the spring may be guided along the definite path as it deflects to acts as a structural member in addition to energy absorbing device.
- Thus, leaf spring carry lateral load, brake torque, driving thrust and shocks.
- It consists of number of semi-elliptical plates called blade or leaves.
- The leaves are given initially curvature or camber so that they tend to straighten under the load.
- The blades vary in length and are held together by a bolt passing through the center acting as a beam of uniform strength.
- The spring is clamped to the axle housing by means of 'U' bolts.
- The longest leaf is known as master leaves, has its end formed in the shape of an eye through which the bolts are passed to secure the spring to its supports.
- The eyes are attached to shackle provided with bushing of anti-friction material such as

02 Mark for construction

bronze or rubber. The other leaves are graduated leaves.

- To prevent digging in the adjacent leaves, the ends of graduated leaves are trimmed in various forms.
- The master leaf has to withstand vertical bending load, side thrust and twisting moment due to presence of stresses caused by these loads so it is usual to provide two full length leaves and rest graduated leaves.
- Rebound clips are located at intermediate position in the length of the spring so that graduated leaves also shear the stresses induced in the full-length leaves when the spring rebound.
- Highly cambered spring provides a 50% suspension but they also increase tendency to jaw (movement about vertical axis). Flat spring reduces tendency of the vehicle to dip (pitching), when brake or accelerate suddenly.
- Use of longer spring gives soft suspension.
- Generally rear spring are kept longer than the front spring. This causes them to vibrate at different frequencies, which prevent excessive bounce.

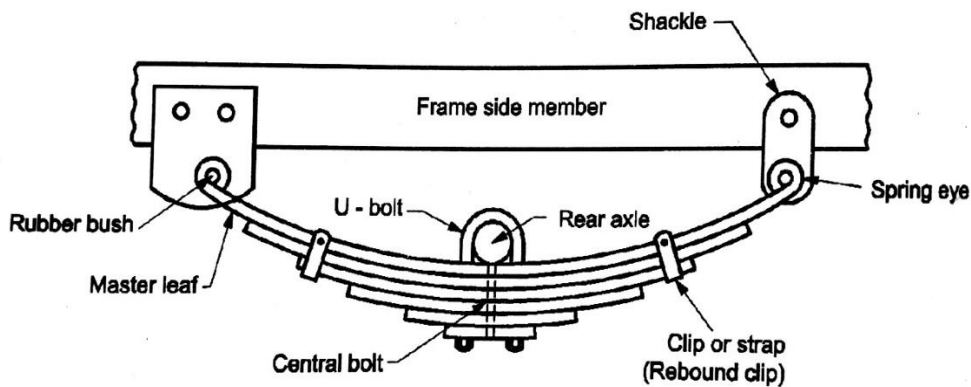

2 Mark for dia.

(c) Explain with neat sketch the bolts of uniform strength.

04 marks

Ans

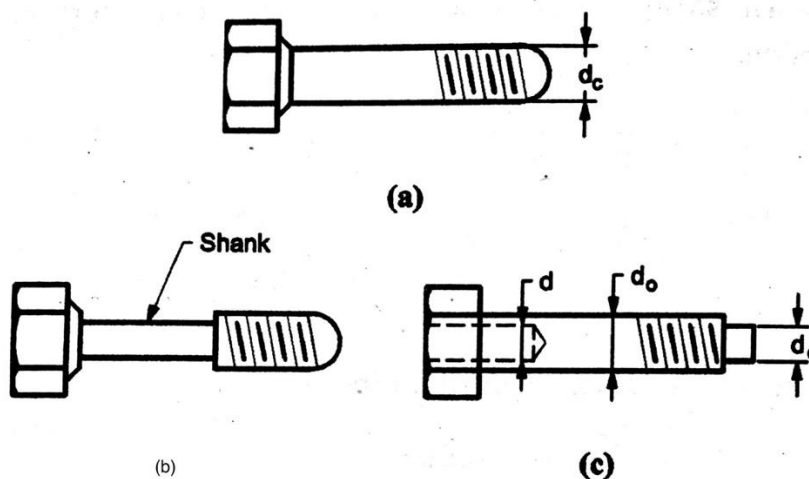

01 Mark

When bolt is subjected to shock load i.e. power hammer, connecting rod, presses, etc. In such cases the bolt is designed to absorb impact load and to resist the torque to prevent the breakage of thread. In ordinary bolt fig (a) the effect of load concentrated on the weakest part of the bolt i.e. c/s area of the root of the thread. The stress in the threaded part will be more as compared to the shank hence the maximum portion of energy will be absorbed at the region

01 Mark



	<p>of the threaded which may fracture the threaded portion.</p> <p>If the diameter of the shank of the bolt is turned to the core diameter of the thread as shown in fig (b) then the shank of the bolt will undergo a higher stress. This means that shank will absorb large portion of energy thus relieving the material at the threaded portion. The bolt in this way became stronger and lighter and it increases the impact load carrying capacity. This gives us bolts of uniform strength.</p> <p>Another method, an axial hole is drilled through the head of the bolt as far as threaded portion; such the area of the shank became equal to the root area of the thread.</p> <p>D = Diameter of hole.</p> <p>d_o = Outside Diameter.</p> <p>d_c = Core Diameter.</p> $\frac{\pi}{4} D^2 = \frac{\pi}{4} (d_o^2 - d_c^2)$ $D = \sqrt{d_o^2 - d_c^2}$	<p>01 Mark</p> <p>01 Mark</p>
(d)	Explain the procedure of selection of ball bearing using manufacturer's catalogue.	04 Marks
Ans	<ol style="list-style-type: none">1) Calculate radial and axial forces and determine dia. of shaft.2) Select proper type of bearing.3) Start with extra light series for given diagram go by trial of error method4) Find value of basic static capacity (C_o) of selected bearing from catalogue.5) Calculate ratios F_a/VFr and F_a/C_o.6) Calculate values of radial and thrust factors.(X & Y) from catalogue.7) For given application find value of load factor K_a from catalogue.8) Calculate equivalent dynamic load using relation. $P_e = (XVFr + YFA) K_a$.9) Decide expected life of bearing considering application. Express life in million revolutions L_{10}10) Calculate required basic dynamic capacity for bearing by relation.11) Check whether selected bearing has req. dynamic capacity, IF it not select the bearing of next series and repeat procedure from step-4 <p>OR</p>	<p>½ mark for each step</p>

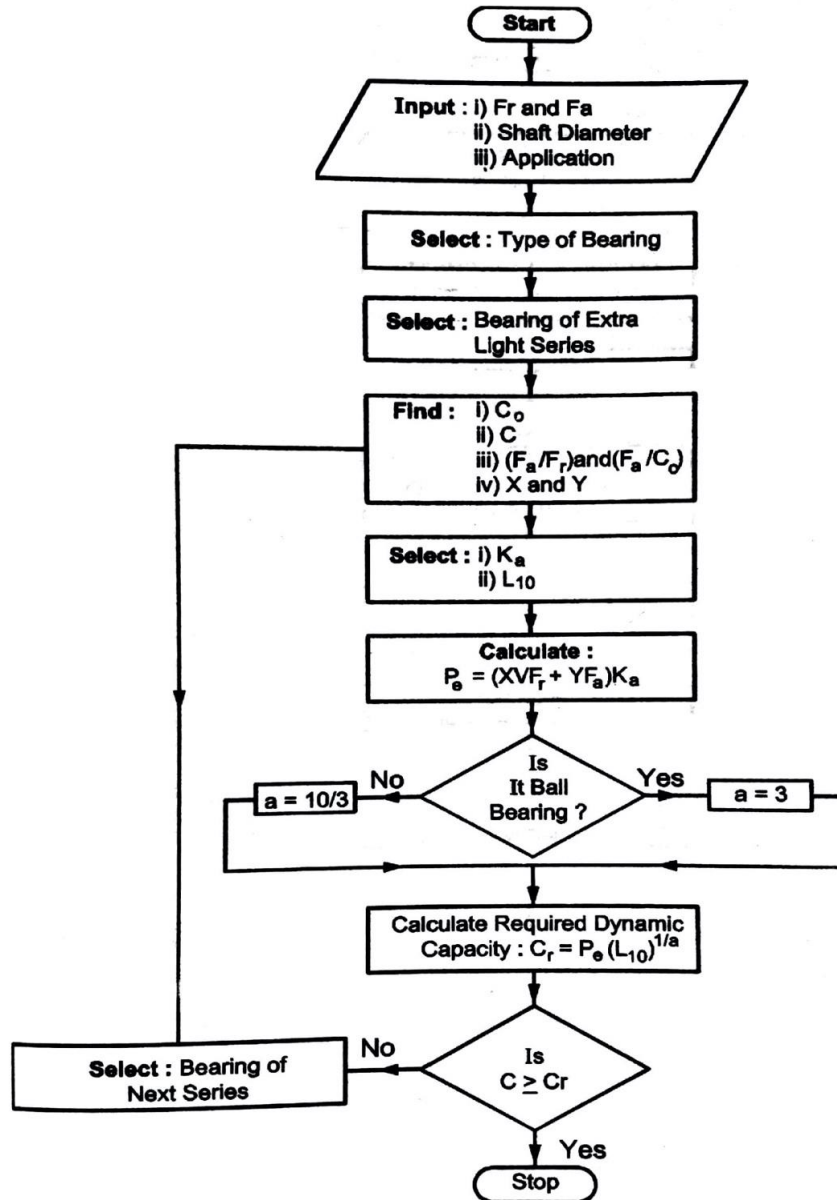

Fig. : Procedure for selection bearing from manufacturer's catalogue

(e) Define the following terms related to ball bearing:

4 Marks

Ans Basic static load rating C_0 :

The basic static load rating C_0 is defined as the static radial load which corresponds to a permanent deformation of the ball and race at the most heavily stressed contact, equal to 0.0001 times the ball diameter.

2 Marks

Basic dynamic load rating:

The basic dynamic load rating is defined as the constant stationary radial load which a group of apparently identical bearing with stationary outer race can withstand for a rating life of one million revolutions of the inner race.

2 Marks